

Big Foot

Instruction Manual

www.LargeScaleForums.com



Thank you

Thank you for selecting the TQ Racing Big Foot RTR! This kit is designed to be fun to drive and uses top quality parts for durability and performance. The instruction manual you are reading was designed to be easy to follow yet thorough in its explanations. TQ Racing wants you to enjoy driving your new Big Foot RTR. If you come across any problems or need some help getting through a step, give us a call and we will do our very best to help you. You can also contact us on the internet at www.dzypower.com.

The caution or attention symbols will warn you about steps that can be very dangerous. Please read and understand the instructions carefully before proceeding.

Safety Guidelines When Operating Gasoline Engines

- ★ This product uses a mixture of gasoline and two cycle oil for fuel. Please use extreme caution when handling gasoline.
- ★ Do not run near open flames or smoke while running your model or while handling fuel.
- ★ Always store fuel in a well ventilated place, away from heating devices, open flames, direct sunlight, or batteries.
- ★ Gasoline is flammable and poisonous. Gasoline powered model engines emit poisonous vapors. These vapors irritate eyes and can be highly dangerous to your health.
- ★ You must only use a mixture of gasoline and two cycle oil as fuel for this engine. Never use glow fuels intended for RC cars.
- ★ Be aware that some parts will be hot after operation. Do not touch the exhaust or the engine until they have cooled.
- ★ After running, please empty the fuel tank before storing the car.
- ★ Keep fuel away from children.
- ★ Store in a well ventilated area.

⚠ Caution

To prevent any serious personal injury and/or damage to property, please be responsible when operating all remote controlled models. Extra attention is called for when operating any fuel powered model. These models can exceed speeds of 40 m.p.h. and use highly poisonous and flammable fuels.



Failure to follow these instructions can damage your kit, and cause serious bodily injury or death.



Failure to follow these instructions can cause injury to yourself or others. You might also cause property damage or damage your kit.

1:5 scale desert buggy

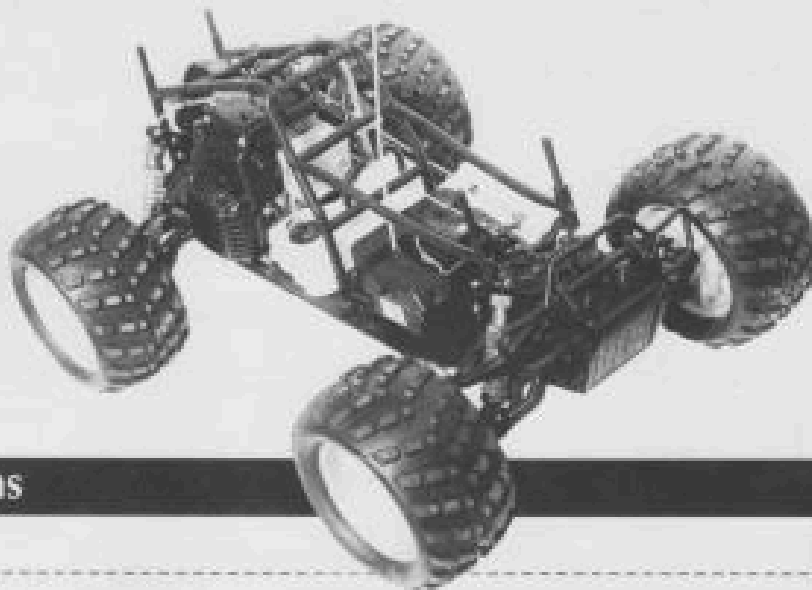

Specifications

Length	700mm
Height	350mm
Width	580mm
Wheel Base (Front to Rear)	480mm
Wheel Diameter	190mm
Weight	6000g
Engine	DZY23SC
Fuel	Mixture oil
Mixing Ratio Gas: Lubricant oil	25:1
Remote Control	Utaba-OEM
Outer Packing Size	800mm X 610mm X 450mm

Characteristics Completed (RTR)

- Packaging chassis
- Super power with Japanese carburetor (waibro)
- Pull start engine
- With muffler and air filter
- Driving by two wheels
- Rear lean gearing differential speed drive
- Super fuel capacity 40 minutes per box
- Super oil spring shock absorber
- Solid aluminous chassis
- Disc brake system
- Japanese remote control and 15kg servoe (Futaba-OEM)

Notice

The following accessories are necessary for your car. You should purchase them from local shops except for those indicated.

Warning: Before operating, you should start the engine for running-in. Otherwise, performance and life of the vehicle will be affected.

Additional tools needed to buy yourself list as follows.

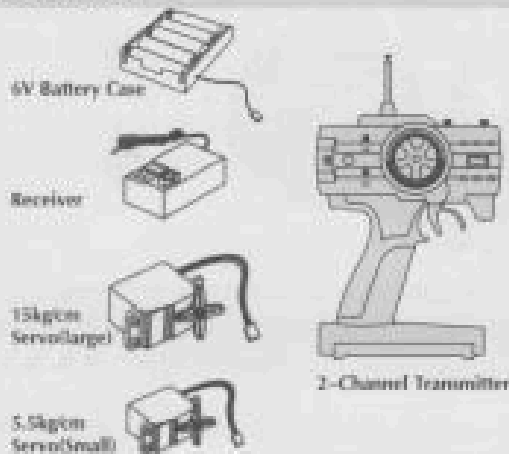

Other tools for purchasing yourself

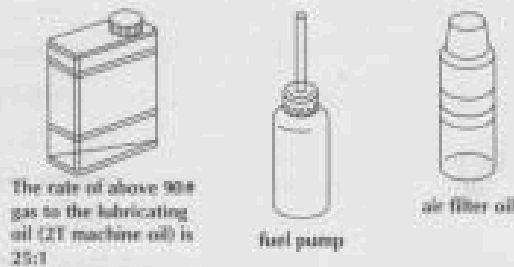

Tools needed for assembly

Tools with car	Tools needed buy yourself
2.5mm	Hobby Knife
1.0mm	
4.0mm	Scissors
5.0mm	
Phillips Driver	Needle Nose Pliers
Spark Plug Wrench	Slider Cutter
Multi Tool	Instant Adhesive

2-channel transmitter system

Please read the instructions for the radio system before use.

The servo must be set at the center position before installation. For this adjustment, switch on the transmitter and the receiver. Set proper-set at the neutral position. Switch off the receiver and the transmitter in succession afterwards. All ways down, the servo will at neutral position for installation.

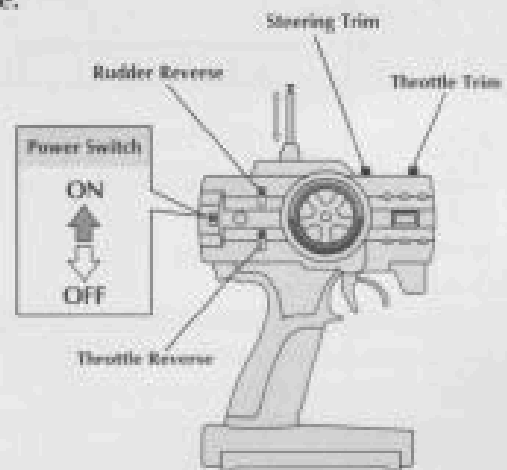
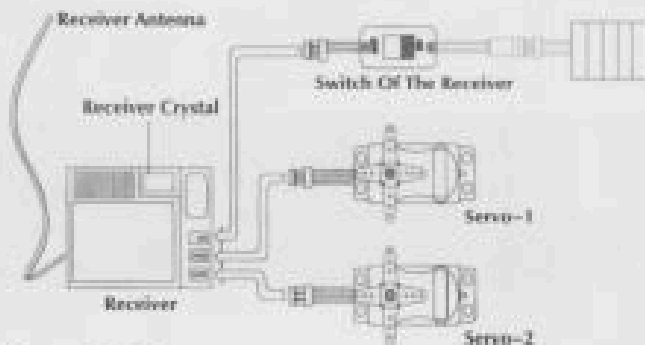

Encase the batteries(BX AA battery or recharge battery)

Troubleshooting

Problem	Reasons	Solution
Engine does not start.	<ol style="list-style-type: none"> 1. Make sure the whole gas course is fluent and the gas pipe is leaky or broken. 2. Check it caused spark when pulling engine. Make sure there are no carbonized phenomena. Never make the engine touch other metal parts. 	<ol style="list-style-type: none"> 1. Clean or replace the gas pipe. 2. Clean or replace the glow plug.
Engine can start but flame out at once	<ol style="list-style-type: none"> 1. No fuel 2. The fuel pipe, the air filter or the muffler is clogged. 3. The carburetor is not adjusted properly. 4. The engine is over-loaded. 5. The glow plug is carbonized or broken. 	<ol style="list-style-type: none"> 1. Fill fuel to the fuel tank. 2. Clean or replace the clogged parts. 3. Readjust the idle, main/low needle adjusting screws. 4. Let the engine cool down completely. 5. Clean or replace the glow plug starter.
Engine does not run well	<ol style="list-style-type: none"> 1. The carburetor is not adjust properly. 2. The gas pipe is leaky or clogged. 3. The glow plug is carbonized or broken. 4. There is some thing wrong with the electric circuit. 	<ol style="list-style-type: none"> 1. Readj just the idle, main/low needle adjusting screws. 2. Install the pipelines between the muffler and fuel tank correctly. 3. Clean or replace the glow plug. 4. Check out the circuit, and solve the trouble.
Hardly operate the vehicle	<ol style="list-style-type: none"> 1. With low battery level in the transmitter and the receiver 2. The receiving effort of the antenna is not well. 3. The servo's proper not is not adjusted properly. 	<ol style="list-style-type: none"> 1. Recharge the batteries or replace new batteries. 2. Extend the antenna in the maximal range. 3. Put the servo in "neutral" place, and then re-adjust it.

Safety precautions

- ★ Run your car after assembling it completely.
- ★ Never change the direction too often and abruptly during ride.
- ★ Never run the car on following places.
 - ★ The place grasses overgrow.
 - ★ Muddy, sandy, or rocky places.
- ★ It possibly happens that turning your car is difficult. Especially, when going upgrade or riding on bumpy places. However, it does not indicate the car has some trouble itself. Please check screws and nuts at all time to avoid looseness.

Warning: To avoid accidents and personal injury, please observe these aspects as follows:

- ★ Handling fuel safely:
 - ★ Only use the fuel outdoors!
 - ★ Only use the especial fuel: mixed with Zn-alkly (above 90#), gas and lubricating oil with a scale of 25:1
 - ★ Never fill fuels indoors, and never use it close to fire and heat of source.
 - ★ Do not swallow fuel or let it get into your eyes.
 - ★ Only store fuel in cool, dry, and dark places. Out of children's reach! Please fasten the cover tightly!
 - ★ Never throw empty fuel cans into fire! Otherwise it may cause explosion!
- ★ Never put fingers or other objects into rotating or moving parts!
- ★ Never touch engine and muffler as soon as use because of the danger of burn.

Operation precaution

WARNING: Never run your car in these situation!
(Unobserved operations will cause accidents.)

- ★ Run your car in spacious places, and never in the following places.
 - ★ On roads or railways.
 - ★ The place where children or people gather.
 - ★ In residential, parks, and hospitals or close to airports.
 - ★ Indoors or in limited places.
- ★ Unobserved operations will cause accidents of personal injury and loss of property.
- ★ Make sure the battery level of the transmitter and the receiver are enough.
- ★ With low battery level, running effect will fall off. The car may be out of control, and even cause severe accidents.
- ★ Keep on guard that someone maybe operate this kind of model at the same time.
- ★ Never use the same frequency with someone else simultaneous! Otherwise, it may disturb the signals, the car may be out of control, and may cause severe accidents.
- ★ If the car runs abnormally, stop running immediately. Check the trouble. You should not operate the car until trouble had been settled completely. Otherwise, further trouble may come out, and cause accidents.

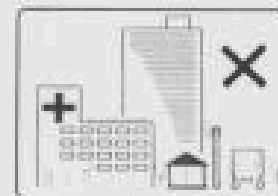

Start the engine

Please read the following instructions carefully before starting the engine.

1. The process of cleaning before driving your car

- ★ For cleaning the engine, 1-2 tank oil use is a standard, and then run your car slowly to run out of another 1-2 tank oil. Always down, the cleaning work is over. The car can run normally.
- ★ Notes: Due to the affect of external environment, you should clean the air filter after running your car more than 1-2 hours. Otherwise, it may affect performance or shorten your car's life.

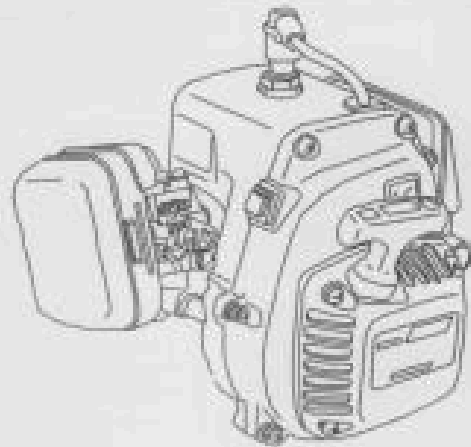

2. Turning on the transmitter and the receiver

- 2.1 Extend the antenna of the transmitter and the receiver, and then switch on the transmitter and the receiver in succession.
- 2.2 While switching on the receiver, make sure the carburetor is at the neutral position.

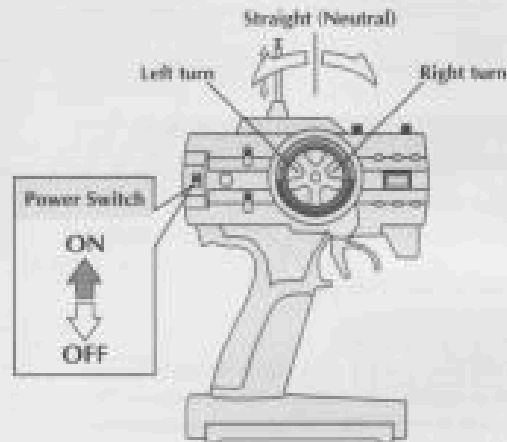

3. Fill the fuel

- 3.1 Fill the special model's fuel, and mix the gas (The Octane level is more than 90#) and the lubricating oil. The rate of the gas to the lubricating oil is 25:1.
- 3.2 Close the fuel tank's cover and fasten it after filling the fuel.

★ Notice:

- 1) Never make alcohol or other inflamer as the fuel. Otherwise, the rubber part of carburetor and the engine will damage.
- 2) Gas is easily inflamed. NO SMOKE!
- 3) To avoid abnormal situation that could possibly happen, make sure the fuel filter, the fuel pipe, and other parts work normally.



4. Starting the engine

- 4.1 Push the front valve several times until securely streaming out oil. (Fig. 1)
- 4.2 Shut down the wind gate (Fig. 2), and turn the accelerograph to the position that spaces 1/4-1/3 place of opening.
- 4.3 Pull the pulling-start rod until engine send out sound of start to start engine. (Fig. 3)
- 4.4 Adjust the wind gate (Fig. 2) to the place which spaces 1/4 position of opening position.
- 4.5 Pull the pulling-starter rod quickly.
- 4.6 Start engine several minutes to prewarm.

Notice:

1. It is necessary that the engine may be choke and, airtight during over-heated situation.
2. Because of over-choke, it is hard to start engine, and may cause the plug starter's wetness.
3. When replacing or drying plug starter, please pull the pulling starter rod to run out of surplus oil of the cylinder.

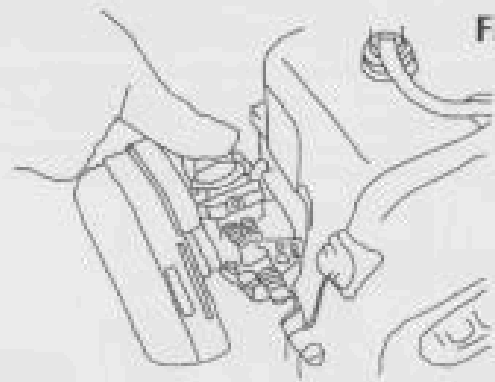

Fig. 1

5. Detailed operations:

- 5.1 The engine has been adjusted to high power and speed.
You need maintain correctly to keep this better performance.
- 5.2 Due to user's diverse operations, we will illustrate details in the instruction manual of car manufacturers.
- 5.3 You should let the engine cool down more than 30 seconds for in low speed racing after valve's fully running.

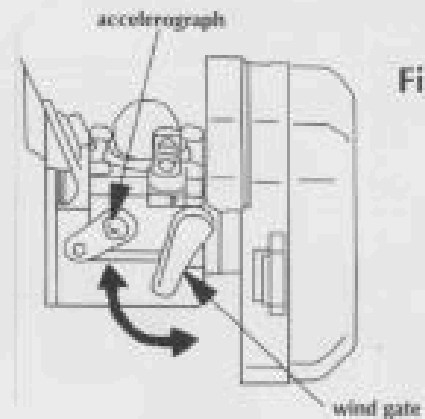

Fig. 2

6. Stop the engine

- ★ The engine will immediately stop running as long as you press the stall switch of the engine. Please refer to the instruction manual (DZY235C) for more details.

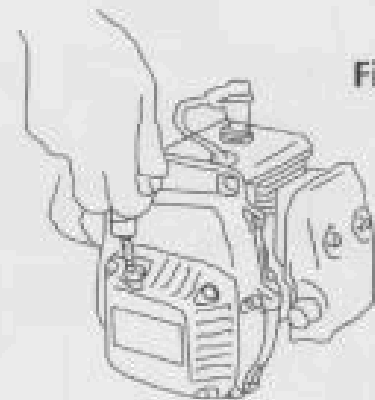
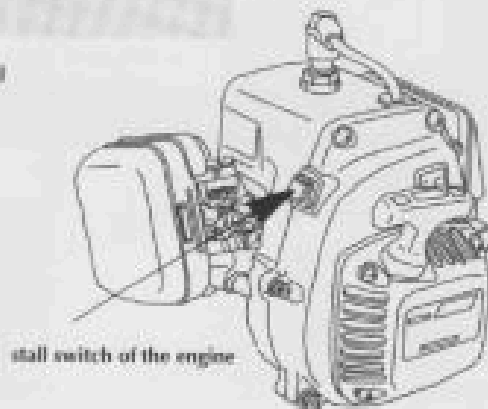

Fig. 3

7. Keep maintainance

Keep the engine clean, and refer to the instruction manual (DZY235C) for more details.



Transmitter Preparation

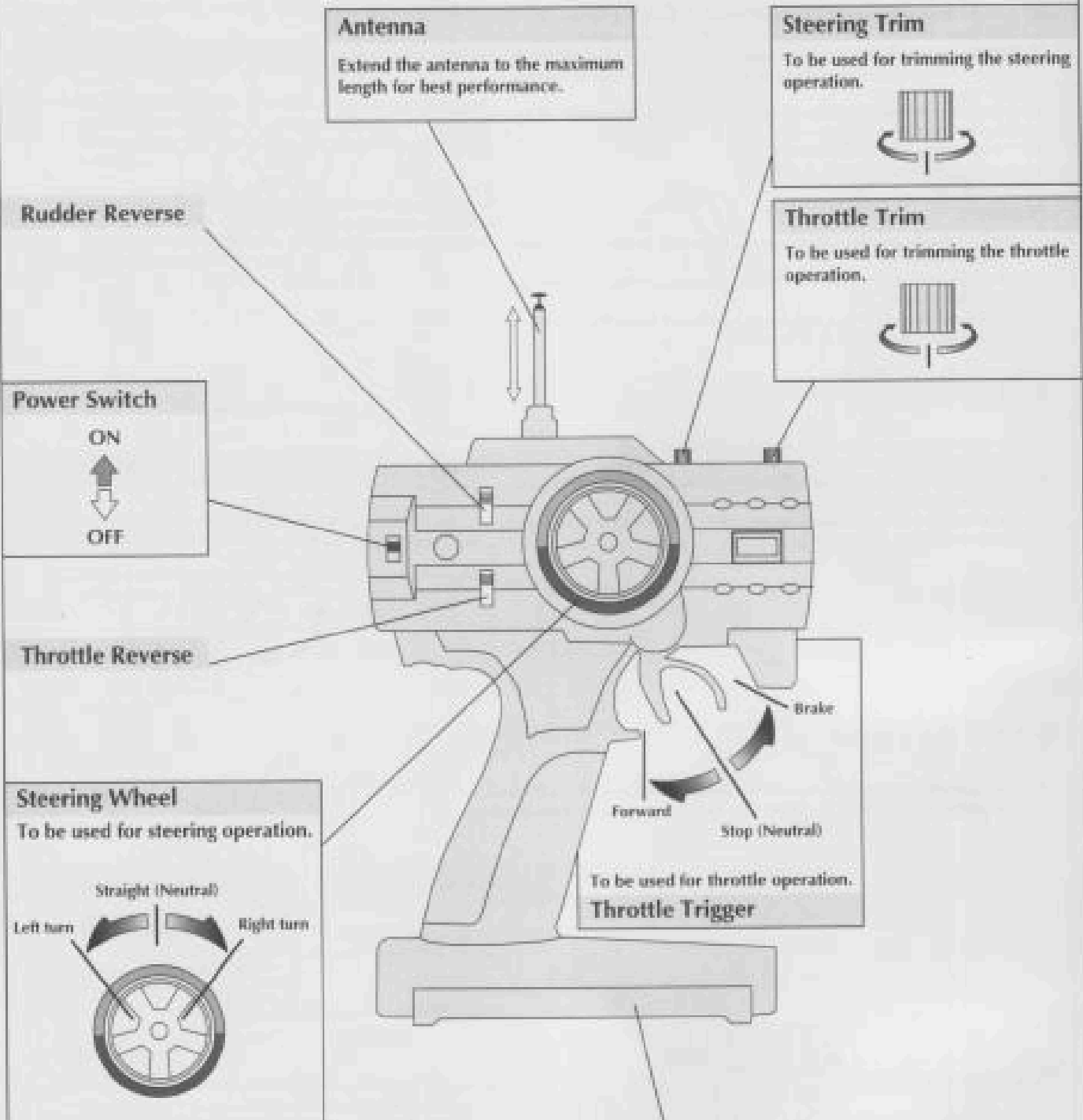

Transmitter Battery Installation

Open battery cover at the bottom of transmitter. Install batteries. Follow the direction of batteries designated in the inside of battery box.



8X AA Alkaline Batteries

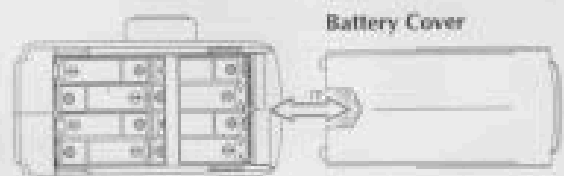

Setup Before Starting

Activating R/C Unit

Turn on transmitter first, then turn on receiver.

Make sure no one else is using the same radio frequency as you are using. Check the radio system and range before every driving session. To properly check the range, have a friend hold the buggy with the engine off and walk to the farthest distance that you plan to operate your model. Operate the controls to make sure the model responds correctly. Do not operate the model if there is any problem with the radio system. If you switch on the R/C car first before the transmitter, you may lose control of the R/C car.

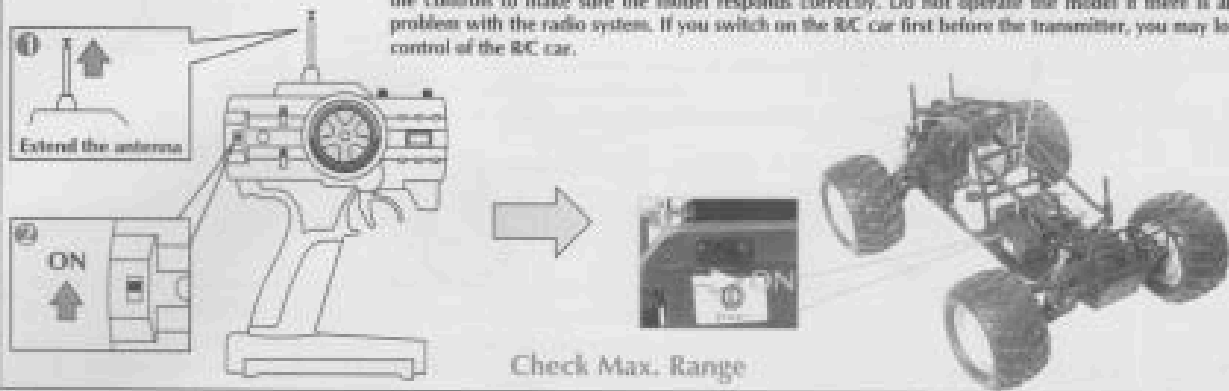

Transmitter Operation

Steering Wheel

Turning the transmitter wheel left and right will make the front tires of the car do the same. Turning the wheel a small amount will make the model perform a wide turn. Turning the wheel a large amount will make the model perform a sharp turn.

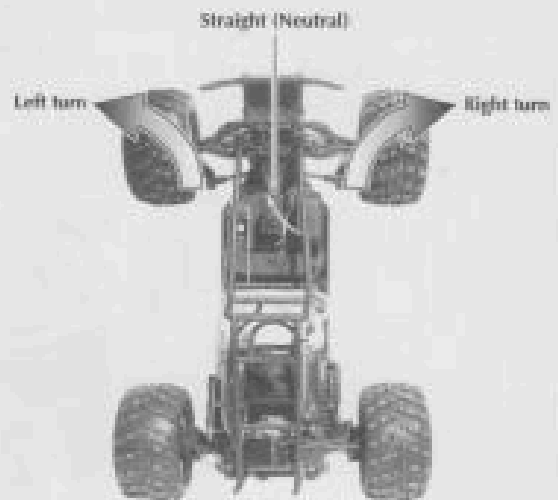
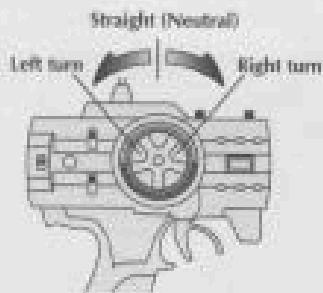

Steering Trim Setup

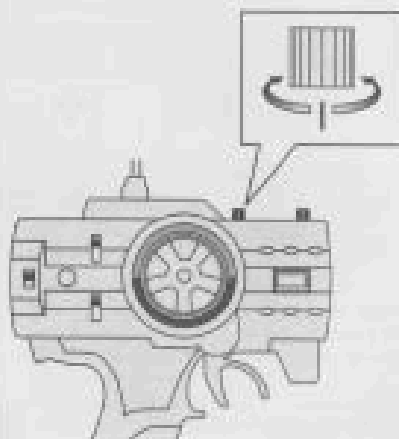

Steering Trim

Turn steering trim to set tires in completely centered position.

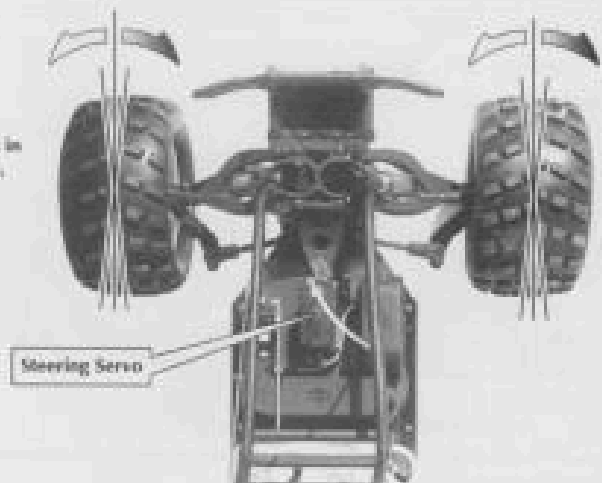

Throttle Trigger

Pull the throttle to drive forward and press it away for brakes.
The more you pull the throttle, the faster the car will move forward.

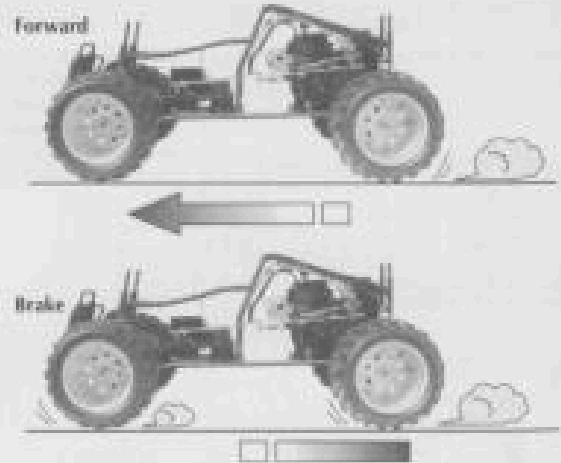
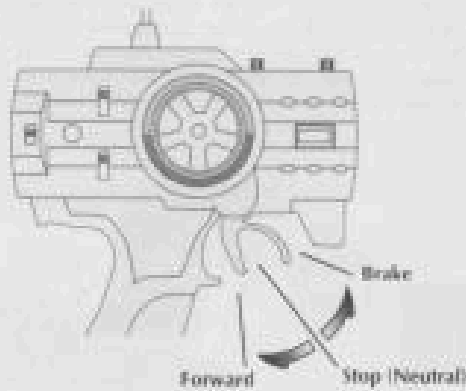

Throttle Linkage Setup

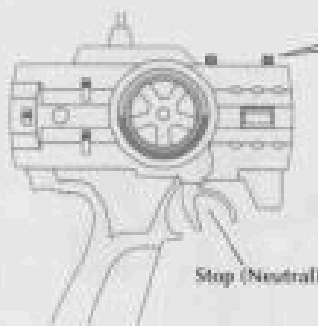

Throttle Trim

Turn throttle trim little by little and adjust rods as shown.
Push the car by hand and push the trigger to test brake function.



Important

If throttle linkage is not set up correctly the car may lose control after the engine is started.

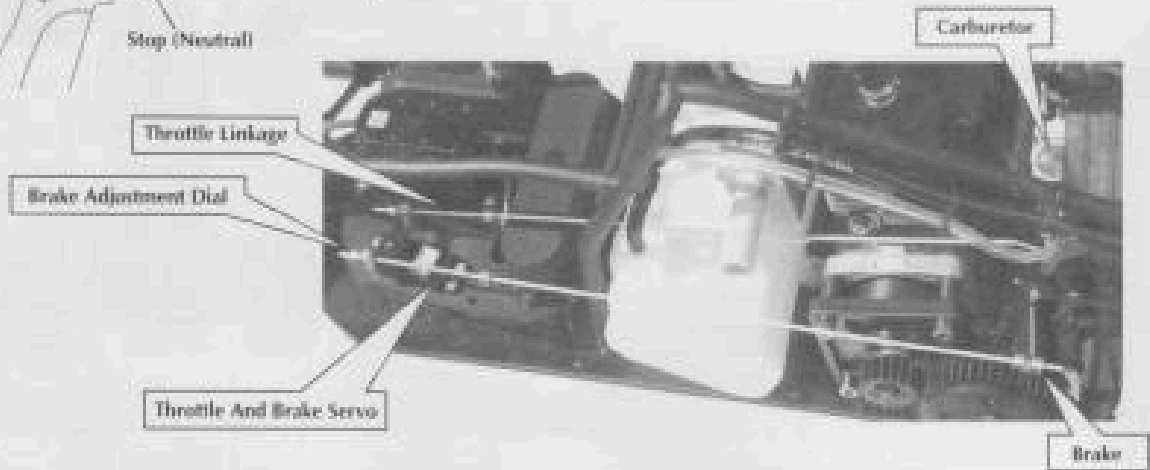

Turning R/C unit off

Turn off receiver first, then turn off transmitter.

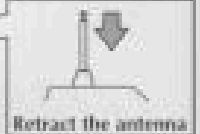
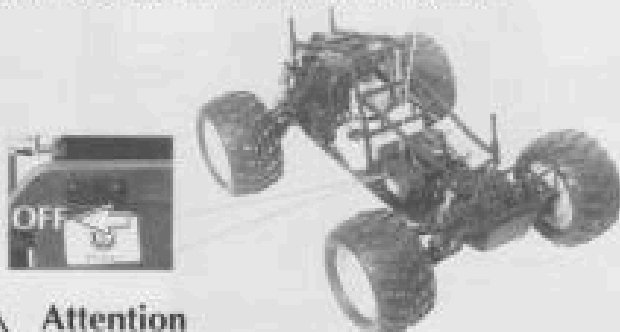

Attention

If you switch off the transmitter first before the R/C car, you may lose control of the R/C car.

TianDi

www.LargeScaleForums.com

Preparation for Fuel



Caution

- ★ This product uses a mixture of gasoline and two stroke oil for fuel. Please use extreme caution when handling gasoline.
- ★ Do not run near open flames or smoke while running your model or while handling fuel.
- ★ Always store fuel in a well ventilated place, away from heating devices, open flames, direct sunlight, or batteries.
- ★ Keep fuel away from children.
- ★ Gasoline is flammable and poisonous. Gasoline powered model engines emit poisonous vapors. These vapors irritate eyes and can be highly dangerous to your health.
- ★ You must only use a mixture of gasoline and two stroke oil as fuel for this engine. Never use glow fuels intended for RC cars.
- ★ After running, please empty the fuel tank before storing the car.



About Fuel

- ★ The Fuelie 23 is a two stroke engine. Use gasoline mixed with two cycle oil (#Z191) as fuel.
- ★ Use 92-98 octane (US 87-93) mixed in a 25:1 ratio with two cycle oil.
- ★ Use only standard 92-98 octane (US 87-93) gasoline. Do not use racing fuel.
- ★ Use only pre-mix two cycle oil to blend with gasoline. Do not use four cycle oil or any oil meant to be used in crank cases.
- ★ Always use fresh pre-mixed fuel. Using pre-mixed fuel more than one month old can damage the engine and carburetor.
- ★ The fuel tank capacity is 750cc. Run up to 40 minutes on one tank of fuel.

Fuel Mixture Chart

The mixture ratio is 25:1 Gasoline : two cycle oil

Gasoline (Octane 92-98 / US 87-93)

Z191 2-Cycle Oil



25

:

1



Mixture Ratio of Gasoline and 2 Stroke Oil

2	liter	•	80	cc	
1/2	Gallon	•	2.6	fl. oz.	
1	liter	•	40	cc	
1/4	Gallon	•	1.3	fl. oz.	
	750	cc	•	30	cc
1 tank	25	fl. oz.	•	1	fl. oz.



Attention

You must keep the mixture ratio at 25:1.

If there is not enough 2-cycle oil, the engine will not have enough lubrication and will be damaged. If there is too much 2-cycle oil, the fuel will not burn efficiently and performance will decrease. Too much 2-cycle oil is safer than not enough.

Mix and store pre-mixed fuel only in containers specifically made for gasoline.

Never use four cycle oil.

Never use gasoline without two cycle oil. The engine will be damaged.

Never use glow fuels intended for RC cars.

Engine Starting and Running

- ★ These instructions will explain the starting procedure. Please read them carefully and fully understand them before starting the engine for the first time.
- ★ Make sure no one is using the same frequency.
- ★ Turn on transmitter first and receiver second. If you turn on receiver first, it can cause you to lose control of the car.
- ★ Make sure linkage setup is correct before running (See Section 2-1).
- ★ After running you must check the car and perform routine maintenance.
- ★ If there is a problem with the engine, press engine OFF switch to shut down the engine.

Important

If there is a problem with the engine, press engine off switch to shut down the engine.



Step 1 Preparation for engine start

Keep the wheels off the ground.

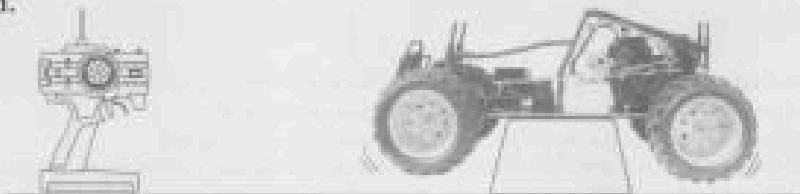

Step 2 Fill Fuel Tank

Clean any dirt from gas cap before removing. Dirt and debris should never get into the fuel tank. Fill the tank with fuel. Make sure the gas cap is screwed on tightly before starting the engine.

You must only use a mixture of gasoline and two stroke oil as fuel for this engine. Never use glow fuels intended for RC cars.

Caution

Be careful not to tilt the car, gasoline may leak from the vent hole.

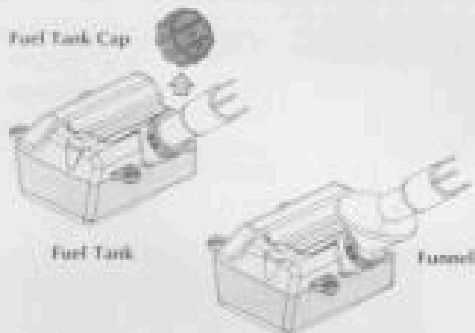

Step 3 Turn on Radio System

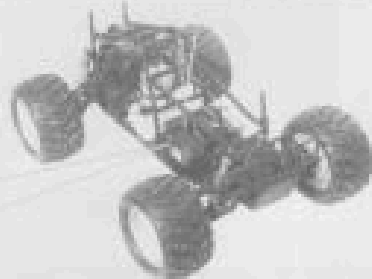
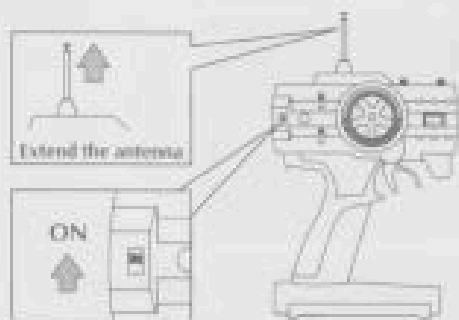

Make sure no one is using the same frequency. Turn on transmitter first, then turn on the receiver. Check the throttle and steering functions and check the radio range before starting the engine. If you switch on the RC car first before the transmitter, you may lose control of the RC car.

Step 4 Priming Engine

To prime the engine, fill the tank with fuel and push the primer bulb until fuel shows in the return tube (Yellow). After the engine has been run for the first time, if fuel shows in the yellow return tube, you do not need to prime the Engine.

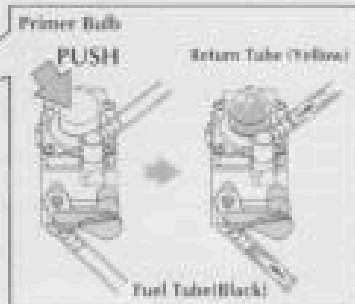

Step 5: Engine Start

Make sure choke lever is in the horizontal position before starting.

Start the engine by pulling the starter cord in short pulls (No longer than 20" max).

The engine must never be run without the air filter in place.

If there is a problem with the engine, press the engine OFF switch to shut down the engine.

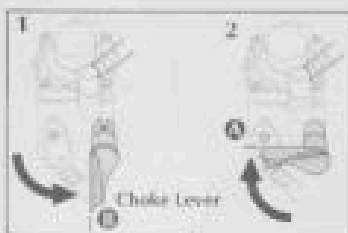

Engine Start Tips

- 1 If you have trouble starting the engine, move the choke lever to the vertical position ②.
- 2 Pull the starter cord until you hear the engine is almost starting. Then move the choke lever back to the horizontal position ① and try starting the engine. If you pull the starter cord too much while the choke lever is in the vertical position ②, you might flood the engine.

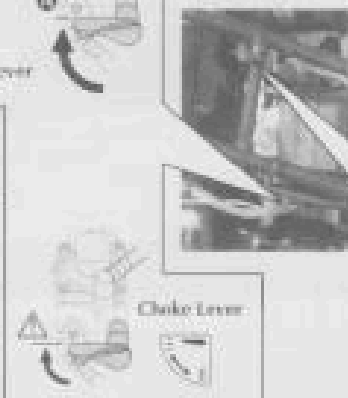

⚠ Important

Engine OFF Switch

If there is a problem with the engine, press engine OFF switch to shut down the engine.

PUSH



Step 6: Enjoy Run!

Steering Operation

Turning the transmitter wheel left and right will make the front tires of the car do the same. Turning the wheel a small amount will make the model perform a wide turn. Turning the wheel a large amount will make the model perform a sharp turn.

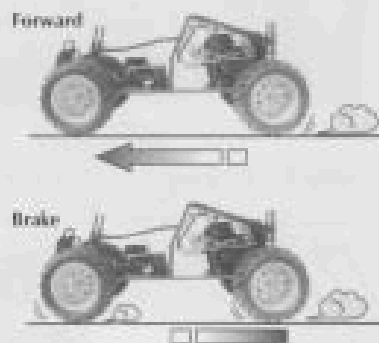
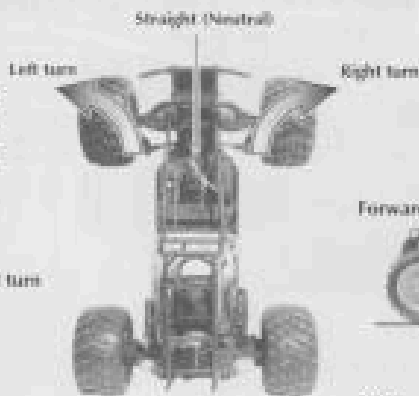
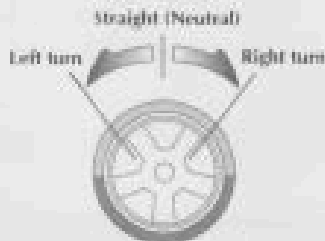

Throttle Operation

Running Pull the throttle to drive forward and push it away for brakes.

The more you pull the throttle, the faster the car will move forward.

Braking When braking, release the throttle to the neutral position to let the car reduce speed before applying the brake.

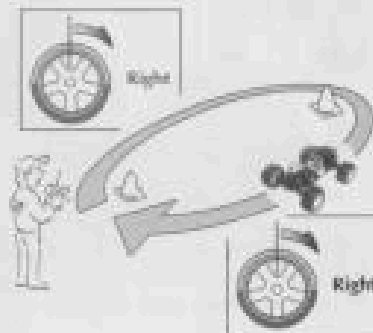
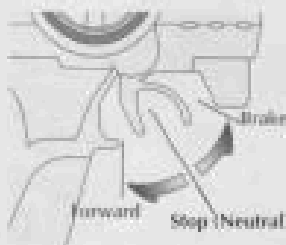

Tips

The Big Foot accelerate very quickly at full throttle. When driving it for the first time, drive at slow speeds using very little throttle until you are used to the car. When the car is running toward the driver, the directions of the steering wheel are reversed.

Adjusting Brake

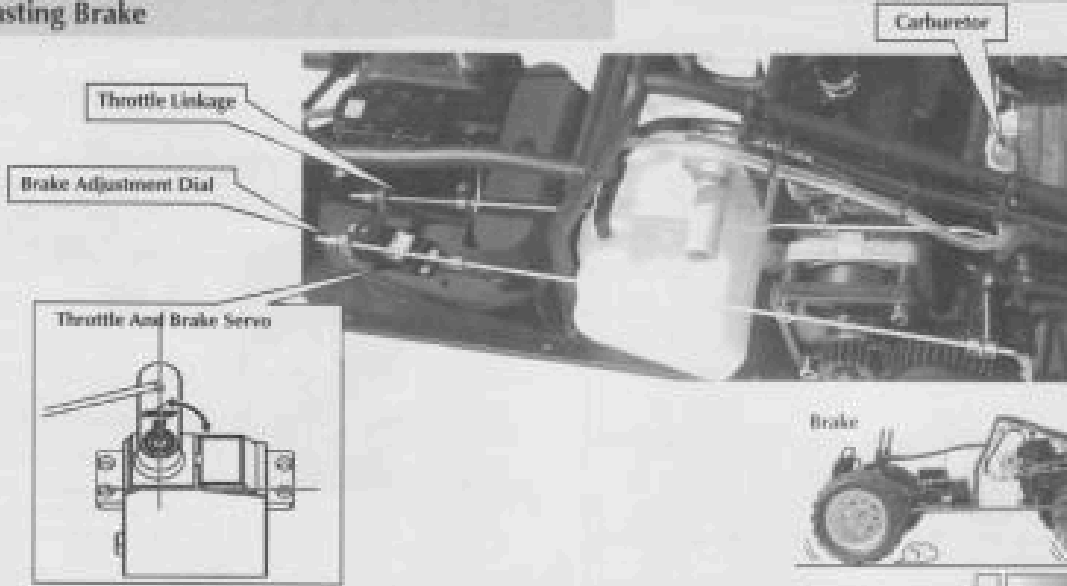

Step 7 Engine Stop

You can shut down the engine by pushing the engine off switch.



Caution
Be careful after running, the engine and muffler will be very hot.

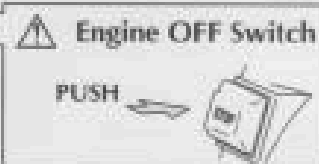

Step 8 Turning RC Unit Off

After the engine is shut off, turn off receiver first, then turn off transmitter.

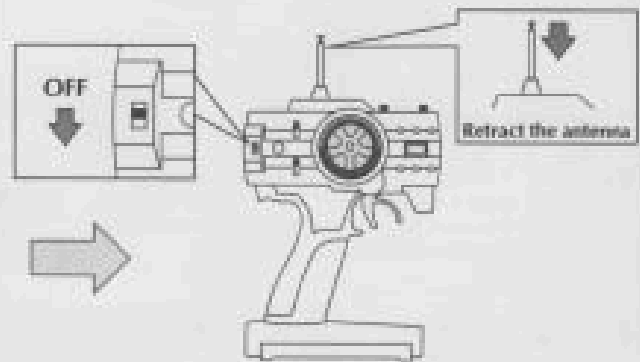
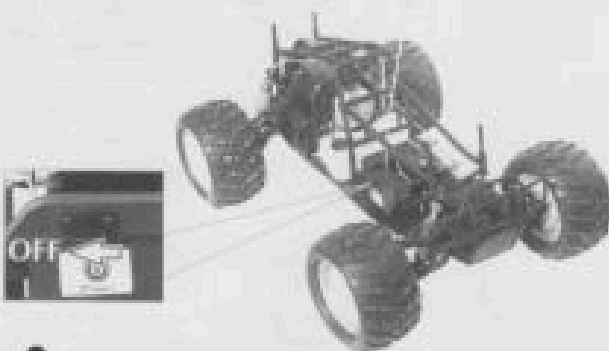

! If you switch off the transmitter first before the RC car, you may lose control of the RC car.

! After Running Maintenance

After running, you should check for damage and perform regular maintenance.

Cautions

The Big Foot can reach speeds over 40 M.P.H. Be careful when driving and avoid hitting people or objects.



Do not run on public streets or highways. This could cause serious accidents, personal injuries, and/or property damage.



Do not run in deep water or puddles. Do not hit humans or objects.



Make sure everyone is using different frequencies when driving together in the same area.

Preparing for Storage

Before storing your Big Foot, follow the directions below.

- Make sure radio is turned off.
- Clean the chassis, lubricate all moving parts and do routine maintenance.
- Make sure the fuel tank cap is tight.
- If the car will be stored for more than one month, drain the fuel tank and run the engine until all fuel is out of the carburetor.

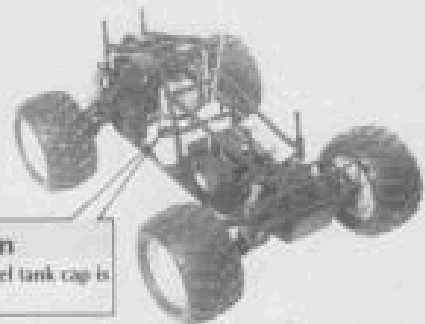

Caution
Make sure the fuel tank cap is tight.

Storage Tips

- Store the car with the wheels off the ground.
- Keep away from heat and fire.
- Store in a well-ventilated area.
- Keep away from children.

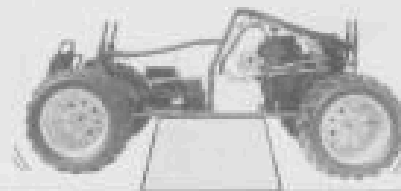

Preparing the Car before the Second Run.

Caution Before running your Big Foot again, follow the directions below and the maintenance schedule.

- 1 Make sure transmitter batteries have sufficient voltage.
- 2 Make sure receiver batteries are fully charged.
- 3 Clean and apply oil to the air filter.
- 4 Make sure fail safe system works correctly.
- 5 Make sure pull starter is working correctly.

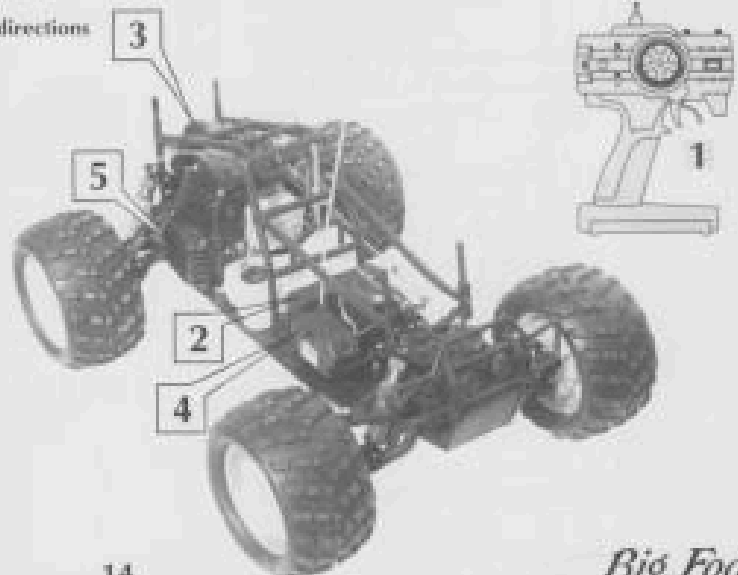

Front shock absorber's diagram

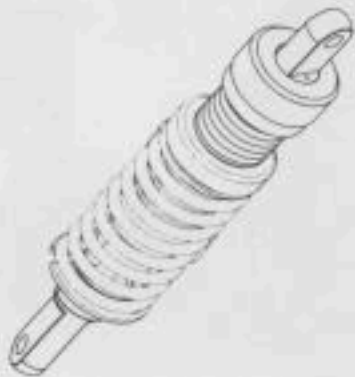
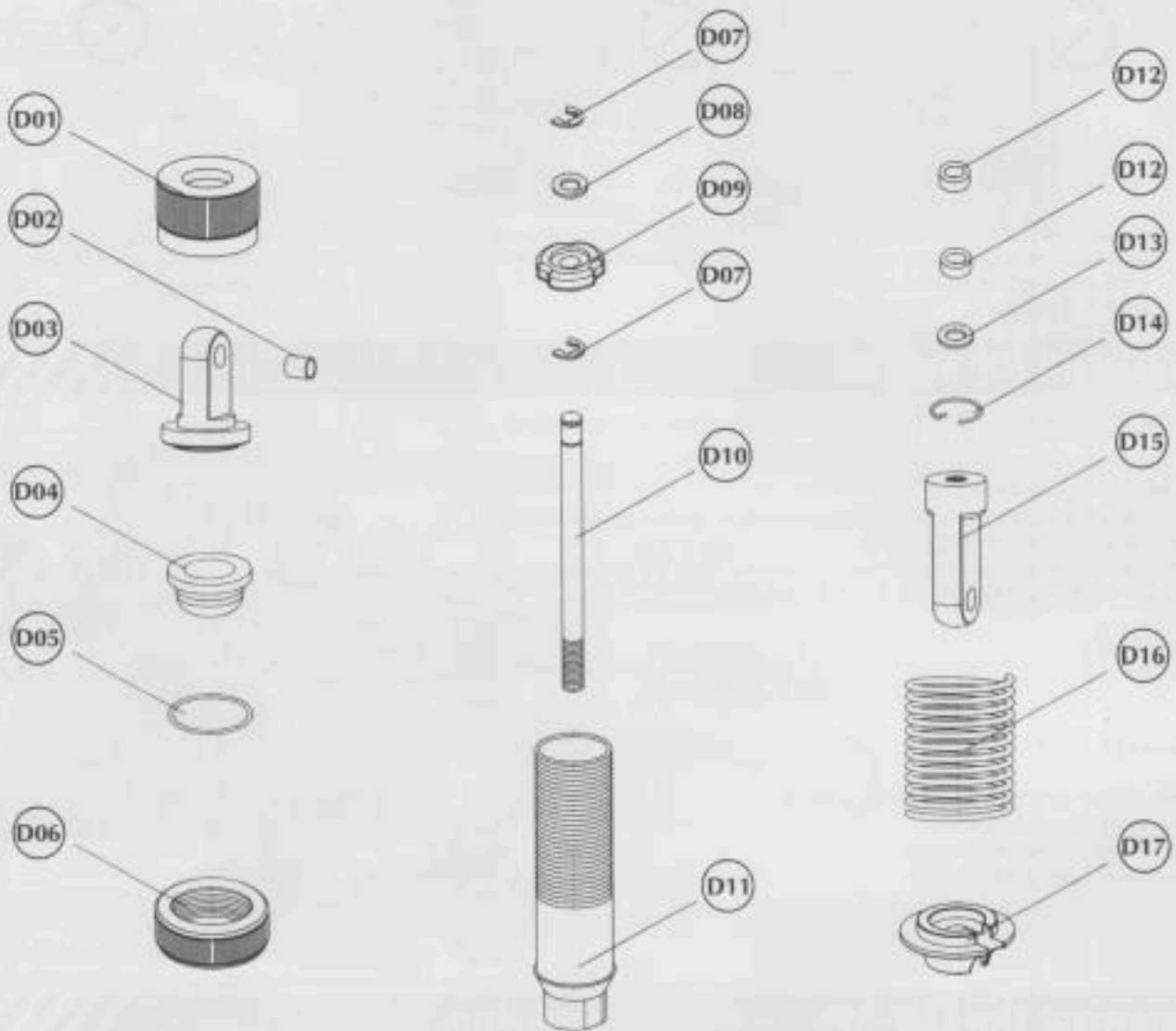

- D01 Cover of shock absorber (upper)
- D02 Shock absorber's fender
- D03 Pedestal of shock absorber (upper)
- D04 Seal case
- D05 O-ring $\varnothing 18.2 \times \varnothing 1.3$
- D06 Ring of shock absorber
- D07 E-ring $\varnothing 3$
- D08 Washer $\varnothing 4 \times \varnothing 8 \times 0.8$
- D09 Shockproof piston
- D10 Axes of shock absorber
- D11 Bore of shock absorber
- D12 O-ring $\varnothing 7.8 \times \varnothing 2$
- D13 Spacer
- D14 Spring septa
- D15 Pedestal of shock absorber (low)
- D16 Spring of shock absorber
- D17 Shock absorber's holder

Rear shock absorber's diagram

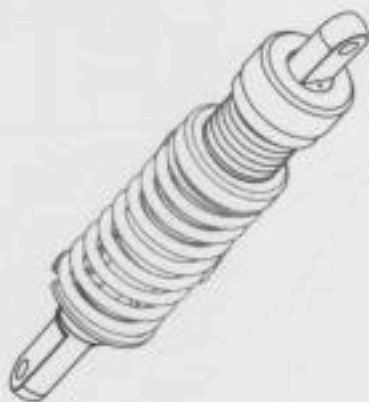
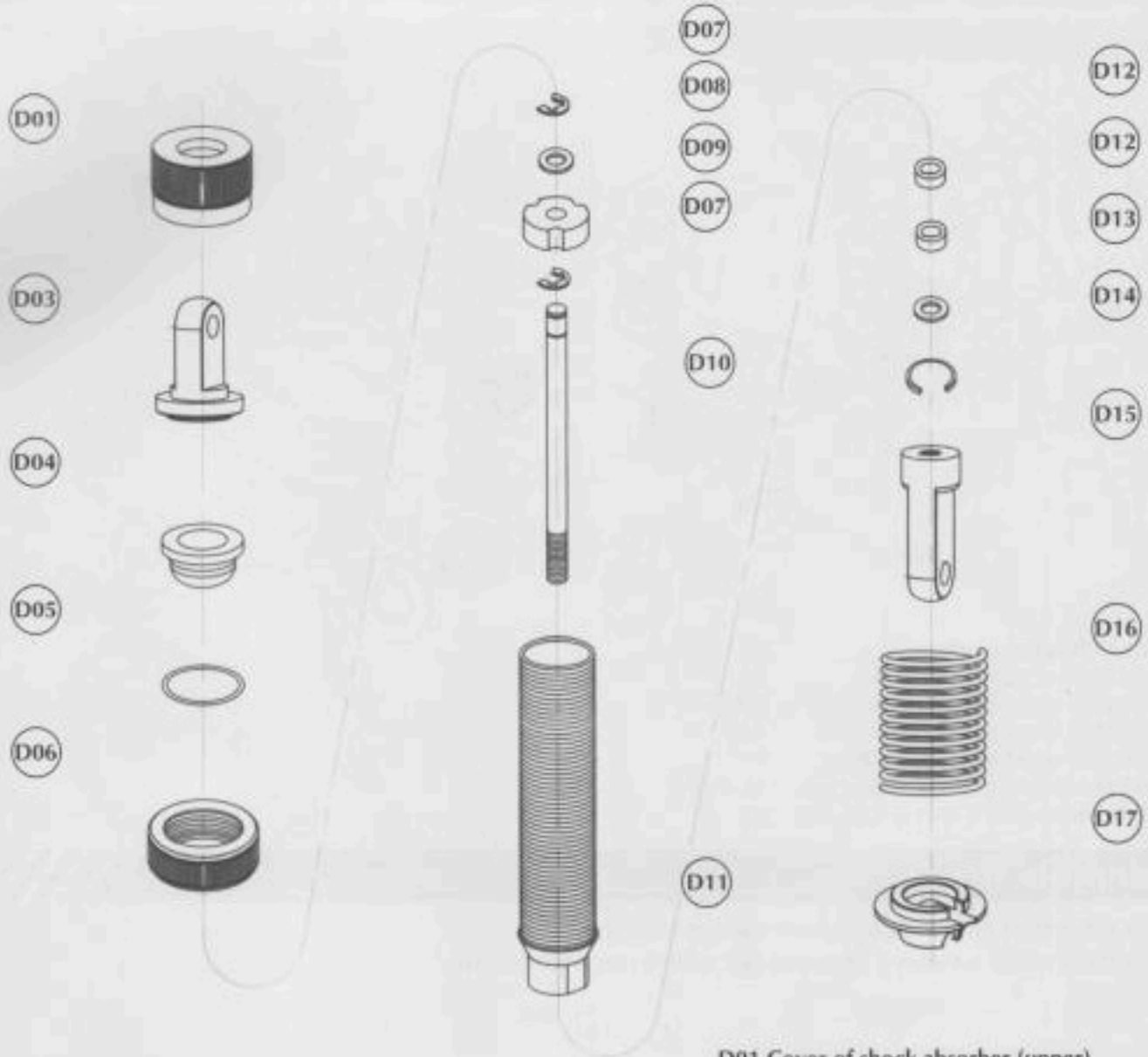

- D01 Cover of shock absorber (upper)
- D03 Pedestal of shock absorber (upper)
- D04 Seal covero $\varnothing 18.2 \times \varnothing 1.3$
- D05 O-ring
- D06 Ring of shock absorber
- D07 E-ring $\varnothing 3$
- D08 Washer $\varnothing 4 \times \varnothing 8 \times 0.8$
- D09 Piston of shock absorber
- D10 Axes of shock absorber
- D11 Bore of rear shock absorber
- D12 O-ring P4 $\varnothing 7.8 \times \varnothing 2$
- D13 Washer
- D14 Spring septa
- D15 Pedestal of shock absorber (low)
- D16 Spring of shock absorber
- D17 Fixed holder of shock absorber

Diff. Speed gear box

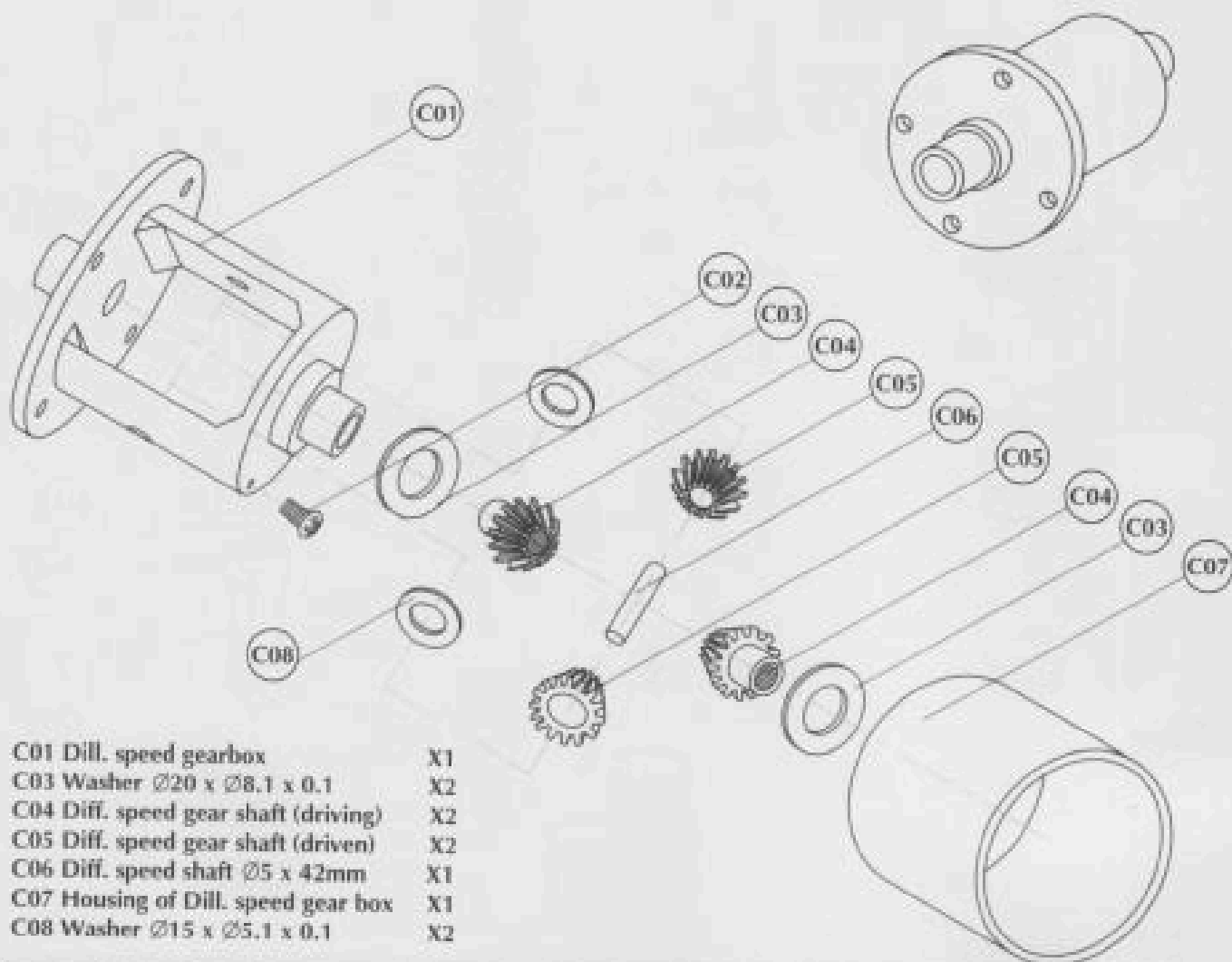

C01 Diff. speed gearbox	X1
C03 Washer $\varnothing 20 \times \varnothing 8.1 \times 0.1$	X2
C04 Diff. speed gear shaft (driving)	X2
C05 Diff. speed gear shaft (driven)	X2
C06 Diff. speed shaft $\varnothing 5 \times 42\text{mm}$	X1
C07 Housing of Diff. speed gear box	X1
C08 Washer $\varnothing 15 \times \varnothing 5.1 \times 0.1$	X2

Assemble tire (F/R)

Press the wheel rim and the wheel sponge into the tire.
Drop the instant adhesive between the wheel rim and the tire.

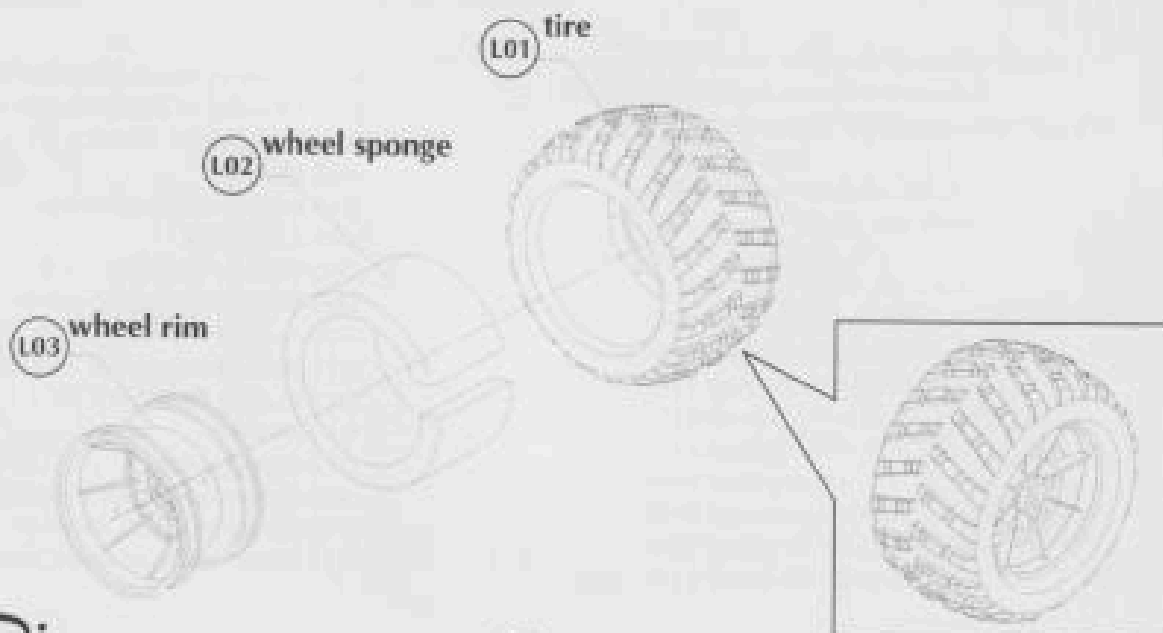



Rebuilding The Engine

There comes a time when your engine just won't provide the performance it did when it was new. When that time comes a rebuild is in order.

Engine Exploded View

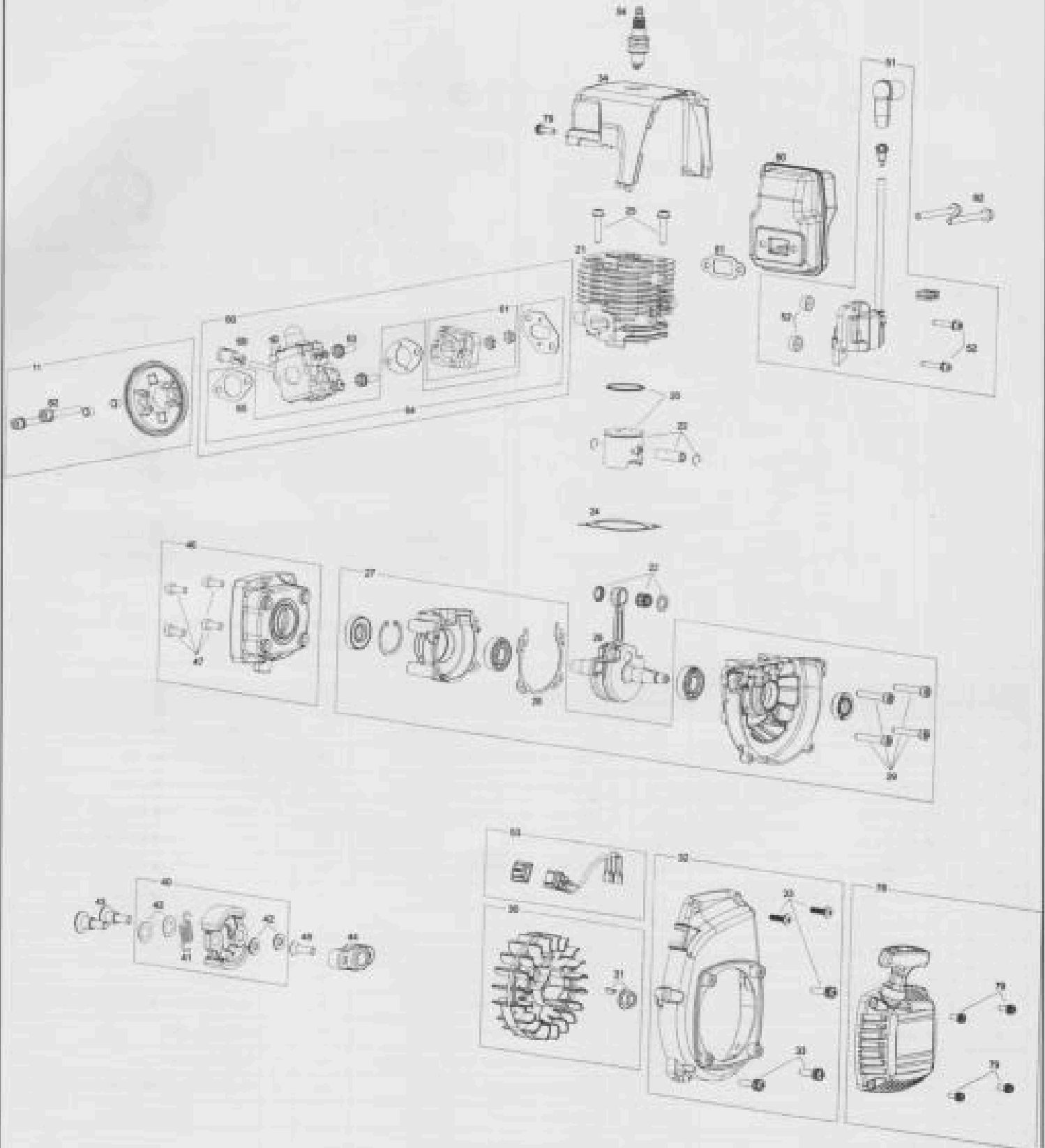

Carburetor Exploded View

80(TQ-986-6)

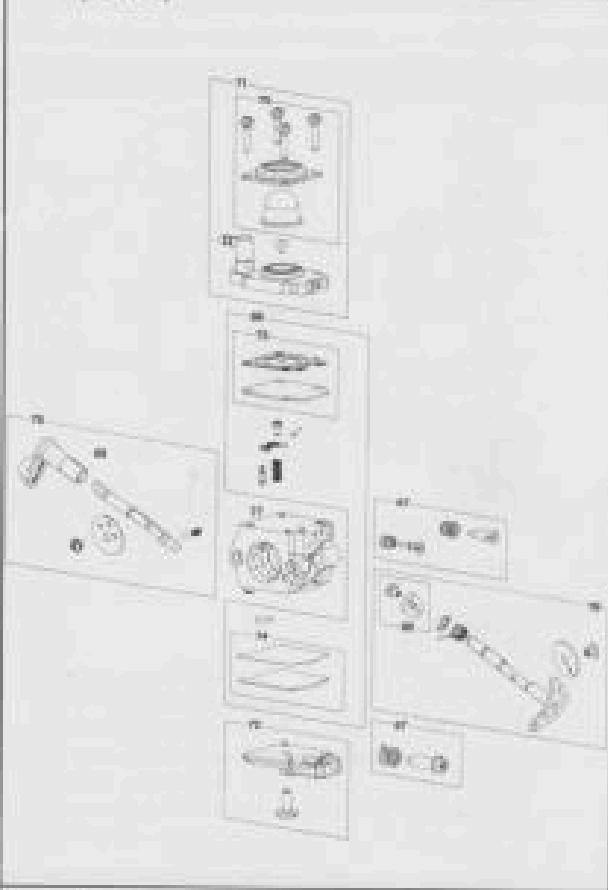

Carburetor Factory Setting

Carburetor

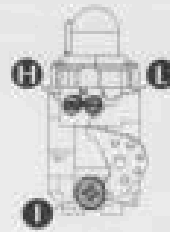

I Low speed needle

Turn low speed needle clockwise until it stops (closed). Then turn counter-clockwise 1/4 turn (open).

L High speed needle

Turn high speed needle clockwise until it stops (closed). Then turn counter-clockwise 1/2 turn (open).

I Idle Adjustment Screw



Use screwdriver to adjust high speed needle.

Carburetor Optional Tuning

If you have problems after the engine is warmed up, use the instructions below for carburetor tuning.

Engine accelerates slowly / hesitates.

I Turn low speed needle clockwise in 1/16 turn increments.

Engine has a low top speed.

L Turn high speed needles counter clockwise in 1/16 increments.

When making adjustments, only turn needles 1/16 turn time. Do not make large adjustments.

Number	Qty	Description	Number	Qty	Description	Number	Qty	Description
01	1	Forke 23 Engine	42	4	Clutch Shoe Washer M6x0.4mm	69	1	Carburetor Choke Arm
11	1	Air Filter Set	43	2	Stop Screw M6x23mm	70	1	Carburetor Primer Set
20	1	Piston Set (3mm Piston Ring)	44	1	Clutch Shoe Holder	71	1	Carburetor Primer Plate
21	1	Cylinder Set	45	2	Flat Head Screw M6x16mm	72	1	Carburetor Pump Cover Kit
22	1	Piston Pin Set	46	1	Clutch Housing	73	1	Carburetor Metering Diaphragm Cover Kit
24	1	Cylinder Gasket	47	4	Cap Head Screw M6x7mm with Spring Washer	74	1	Carburetor Pump Diaphragm Kit
25	2	Flanged Cap Head Screw M6x23mm	51	1	Ignition Coil	75	1	Carburetor Choke Shaft Kit
26	1	Crankshaft Assembly	52	2	Ignition Coil Screw	76	1	Carburetor Throttle Shaft Kit
27	1	Crankcase Assembly	53	1	Engine Stop Switch	77	1	Carburetor Body
28	1	Crankcase Gasket	54	1	Spark Plug / CH875	78	1	Pull Starter
29	4	Cap Head Screw M5x28mm	58	1	Carburetor (TQ-986-6)	79	4	Cap Head Screw M4x15mm With Washer
30	1	Flywheel Set	61	1	Carburetor Spacer	80	1	Exhaust Muffler
31	1	Flywheel Lock Nut M7 And Key Set	63	2	Flanged Cap Head Screw M6x28mm	81	2	Exhaust Gasket
32	1	Flywheel Cover (Black)	64	1	Carburetor Gasket Set	82	2	Flanged Cap Head Screw M6x32mm
33	4	Flywheel Cover Screw Set	65	2	Air Filter Gasket			
34	1	Engine Cover (Black)	66	1	Carburetor Maintenance Kit			
40	1	Clutch Shockspring Set (2000 RPM)	67	1	Carburetor Needle Set			
41	2	Clutch Spring (2000 RPM)	68	1	Carburetor Throttle Arm			

TianDi

19

www.LargeScaleForums.com

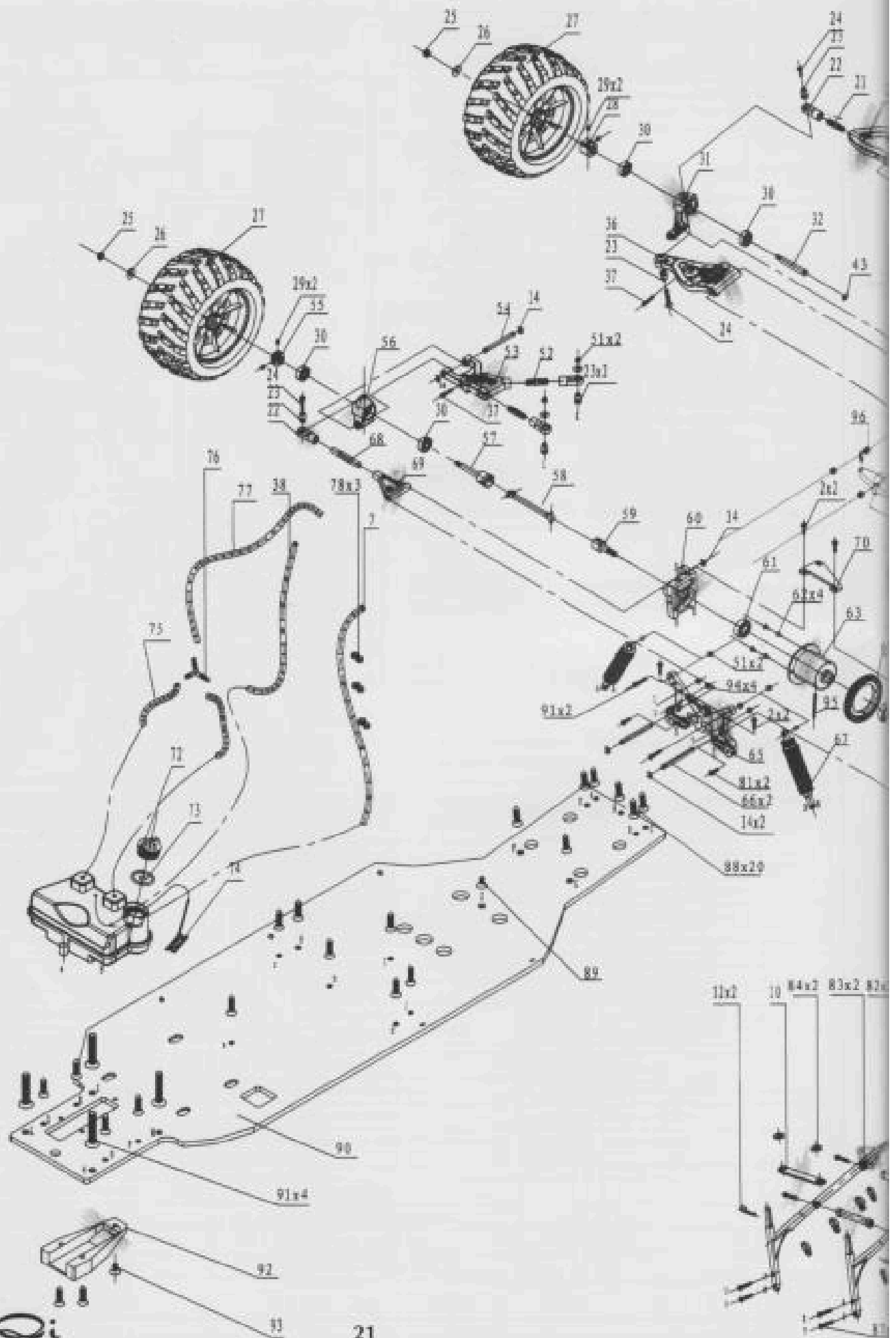

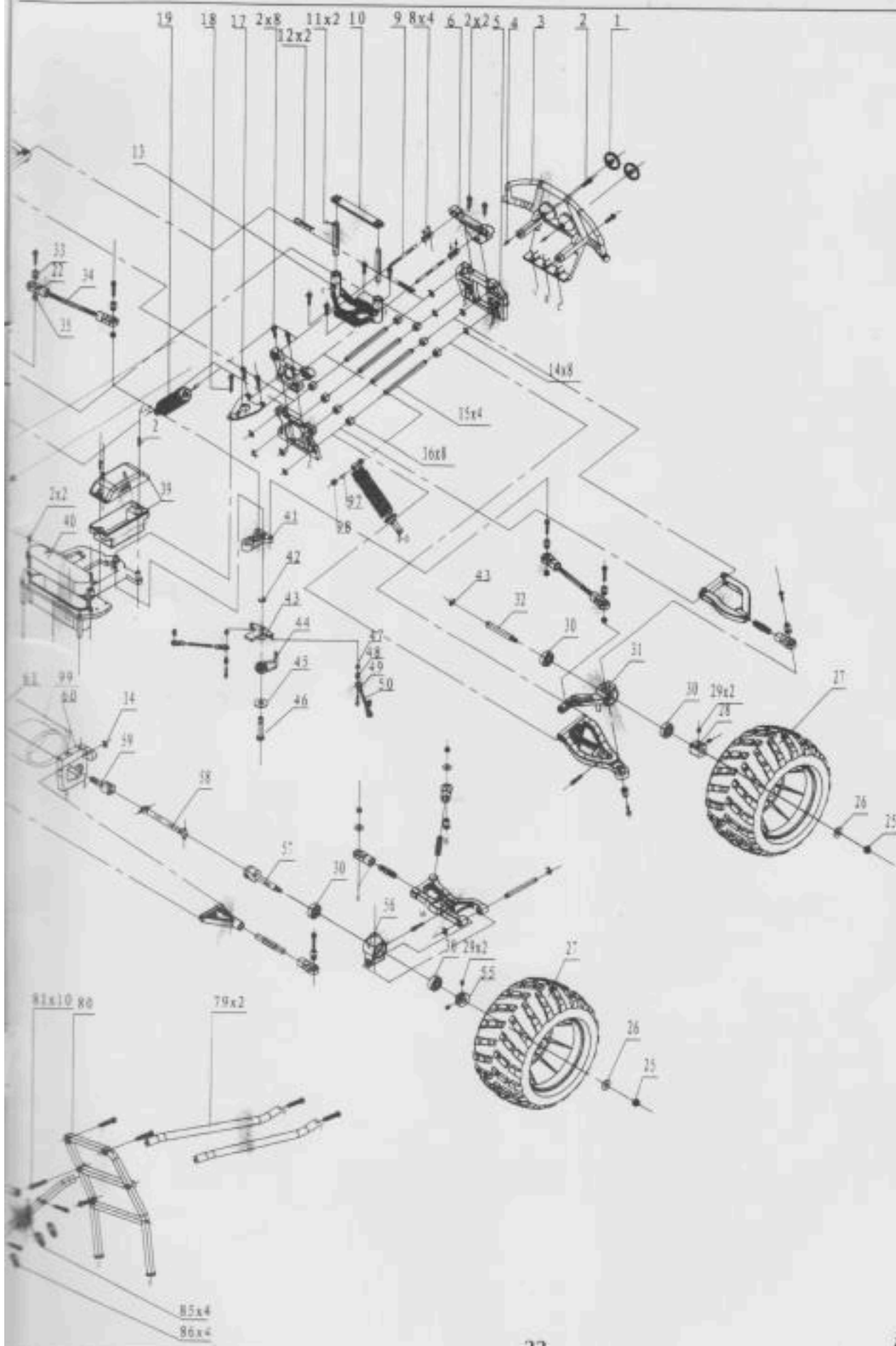



READY TO RUN
RTR
R/C CAR

